

Phebus planetary mixer

A planetary mixer that revolutionizes your baking
Range from 80 to 200 L

Easy, intuitive aeration,
emulsification, crumbling
and whipping.



- **Digy touchscreen interface** 
 - ✓ Programmable mixing speed and duration
 - ✓ Save up to 100 recipes with 20 phases each
 - ✓ 5 adjustable tool speeds
- **Stainless steel paddle and scraper**
Other tool as optional add-ons, easily interchangeable thanks to the quick attachment system
- **Stainless steel grid and removable transparent protective screen with hatch** for adding ingredients during mixing
- **Stainless steel bowl on castor wheels**
Bowl height adjusted for the user
- **Asymmetric feet** for an optimized workspace



Flush drain plug
at the bottom of the tank



For more information:



Video



Ergonomics
sheet



Commercial
documentation



Recipe examples



Contents

Planetary mixer Phebus

General Features



- All stainless steel planetary mixer
- Interface tactile Digy - 5 adjustable speeds
- Stainless steel bowl with drain plug on castor wheels
- Stainless steel paddle and scraper
- Stainless steel grid with hatch and removable protective screen
- Automatic bowl detection, mounting and lock
- Assisted and secure raising and lowering of the head
- 380/ 400 V - 3 phases + Earth - 50Hz (any other specific voltage available and free of charge providing that it is technically possible)
- Power: 7,5 kW - Intensity: 20 A
- IP 54

>> Conditions tarifaires spécifiques



Paddle and scraper included

Phebus 80	Code: B501P0802	Upon request
Phebus 100	Code: B501P1002	Upon request
Phebus 150	Code: B501P1502	Upon request
Phebus 200	Code: B501P2002	Upon request

Optional extras

B10534403	80 L stainless steel bowl on wheels	Upon request
B10531883	100 L stainless steel bowl on wheels	Upon request
B10531847	150 L stainless steel bowl on wheels	Upon request
B10574288	200 L stainless steel bowl on wheels	Upon request
	Stainless steel spiral	Upon request
	Stainless steel whip	Upon request
	Stainless steel whip with removable wires	Upon request
	Full anti-spill cover	Upon request

	Phebus 80	Phebus 100	Phebus 150	Phebus 200
Total bowl volume (l)	80	100	150	200
Weight (kg)	1020	1030	1040	1100
Dimensions (mm)				
Width (A)	1190	1190	1190	1190
Height closed (B)	1850	1850	1850	1850
Height open (B')	2220	2310	2420	2420
Depth (C)	1430	1430	1430	1430
Bowl height (D)	1000	1000	1000	1000
Hatch height (E)	1150	1150	1150	1150

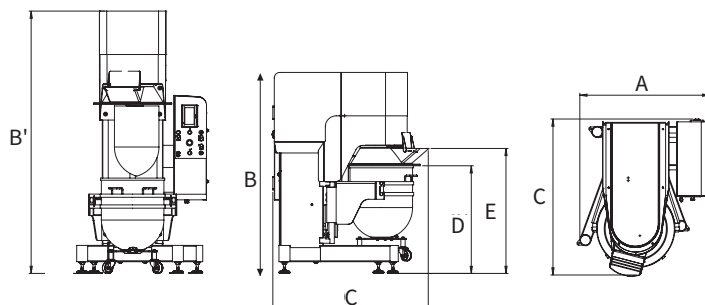

See conditions on page 5